

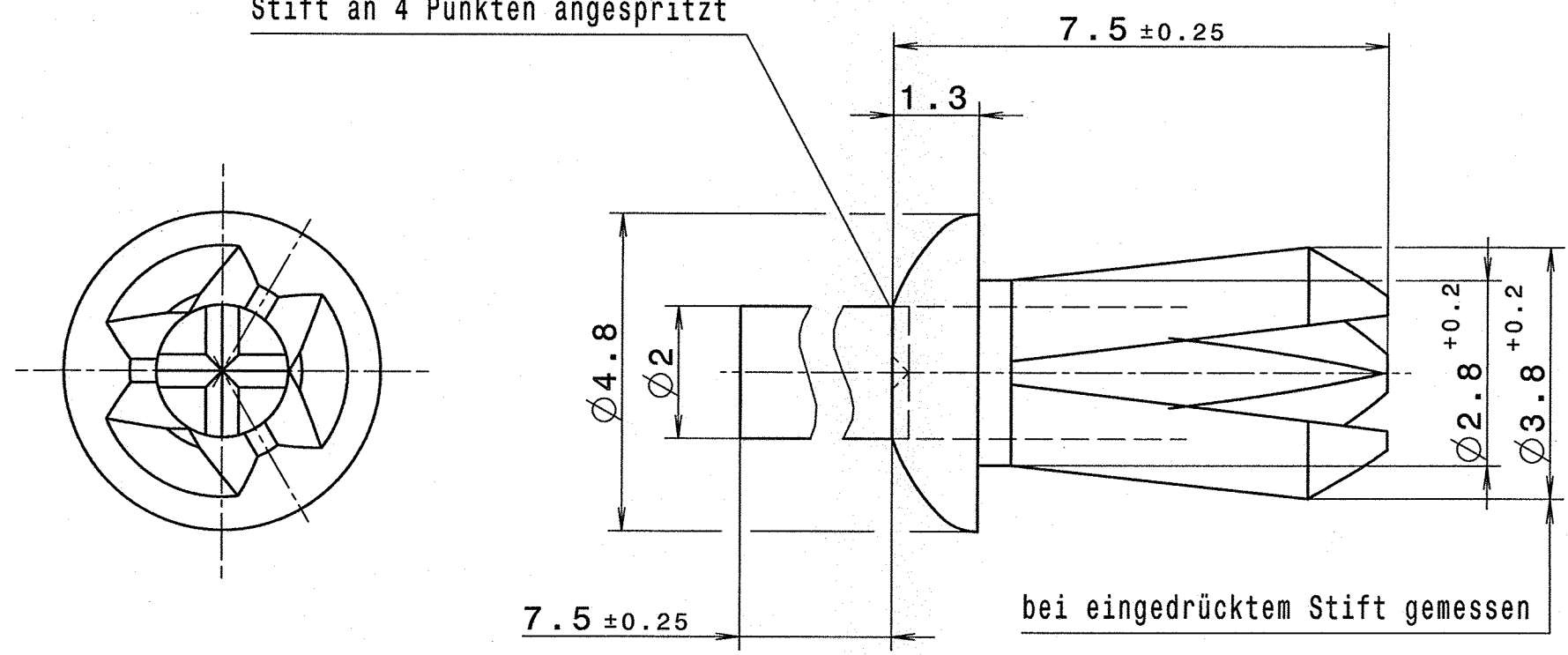

Stift an 4 Punkten angespritzt



bei eingedrücktem Stift gemessen

>400 <= 1000	±2
>120 <= 400	±1.5
> 30 <= 120	±1
> 6 <= 30	±0.5
<= 6	±0.25
Winkel / Angle	±3°

Allgemeintoleranzen fuer Nennmaße ohne Toleranz. General tolerances for nominal dimensions without specified tolerance.

012694 001	schwarz black	SW	7000
012694 000	farblos nature	FL	0000
Teil-Nummer / Part-no.	Oberfläche / Farbe / Finish / colour	Kennzahl / Code number	
Ausführung / Execution			

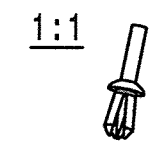

Bef.-Loch ø / Fastening hole ±0.05	Bef.-Dicke / Fastening thickness s
3	0.8
3.1	1.8
3.3	2.5
3.4	3
3.5	4
3.6	4.5

Ea	-	Neue Urzeichnung / 3D	09.01.08	kü
Ind.	kommt vor / how often	Beschreibung / Description	Datum/Date	Name
Aenderungen / Modifications				
Format DIN A-		SPEZIALBEFESTIGUNGSSYSTEME WELTWEIT / ENGINEERED FASTENERS WORLDWIDE		
Bei Verstaendnisproblemen beantragen Sie bitte beim Absender die deutsche Fassung vor jeder Anwendung. "CONDITIONS OF USE" This drawing and all information (the "Drawing") disclosed are the exclusive property of A. Raymond. By using this drawing the Addressee acknowledges and accepts that this drawing (1) is covered by A. Raymond intellectual property rights or know-how and (2) is provided under the following conditions who represent a Deposit Agreement. This Drawing is for Addressee internal use only limited to its estimation. Without prior written consent of A. Raymond, no permission or rights for any purpose, is hereby granted, such as, without any limitation, (1) the copy, in part or entirely and/or (2) the presentation, in part or entirely, to any other third party outside the Addressee company or in the company but with no interest (3) and/or the distribution of the Drawing, in part or entirely, in any medium (4) and/or the creation of any derivative work. In case of breach of these conditions, Addressee shall indemnify A. Raymond from and against all damages (compensatory or consequential), costs, expenses and charges, caused or arising out of or attributable to its willful misconduct, fraud, negligence, infringement of A. Raymond Intellectual Property rights. If the Addressee does not accept these conditions, please notify A. Raymond sender immediately.				
Dateiname/ Filename	012694_C_01			
Ersatz fuer/ Substitute for	12 694.555 Ind. 4 vom 21.08.1992	Proj.-Nr./ Proj.-No.	----- K	RASCH- Code CAF--
Schutzrechte/ Patent rights	vorbehalten / all rights reserved			
Gepr./ App.	F.-gepr./ Produktion	A.-gepr./ Quality	S.-gepr./ Patent app.	
Maßstab / Scale	Allgen.Tol. wenn nicht anders angegeben/ General tol. unless otherwise specified	Datum/ Date	09.01.2008	
10:1	sh. Tabelle / see table	Gez./ Drawn	B. Kühnle	
Oberfl. Behandlg./ Finish	---			Kennzahl/ Code number ----
Werkstoffbehandlg./ Material treatment	---			Blechdicke/ Mat. Thic. DIN EN 10140 ----
Werkstoff/ Material	POM C Standard			Mat.-Code/ 5555
Benennung/ Partname	Spreizniet expansion rivet			
Teil-Nr./ Part-No.	012694 000			C
-CAD-CATIA-V5R16		Format: DIN A3	-Zeichnung=DIN A	Env: --- Dir: ---