

3D-Ansicht
1:1

Gewindedurchzug kann nur mit
lehrenhaltiger M4 Schraube
geprueft werden.

Schwergaengigkeit des Gewindes
durch metallhaltige Korrosions-
schutzbeschichtung zulaessig.

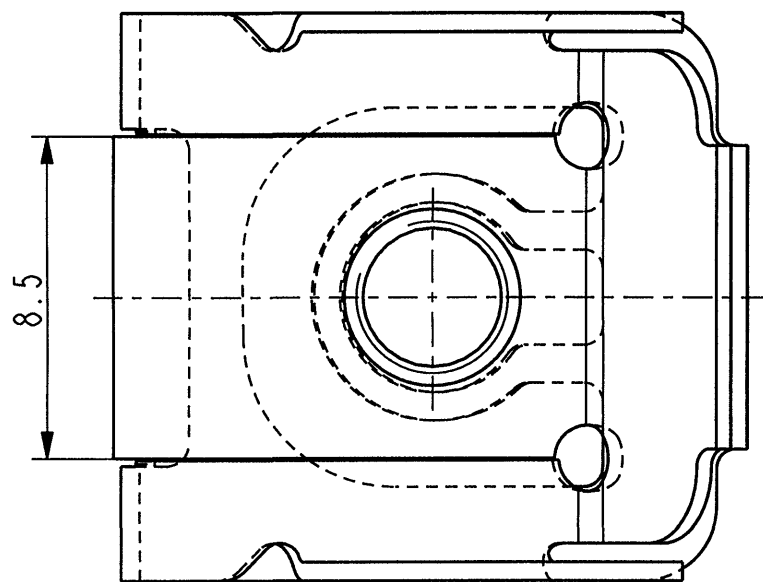
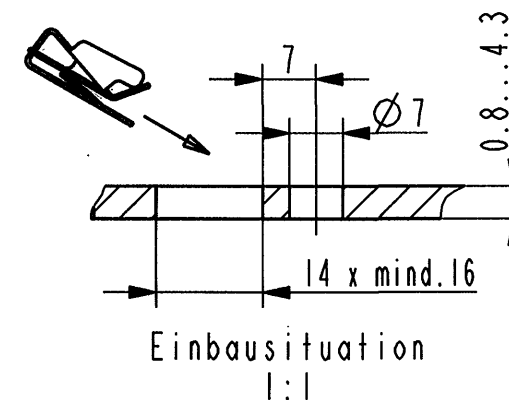
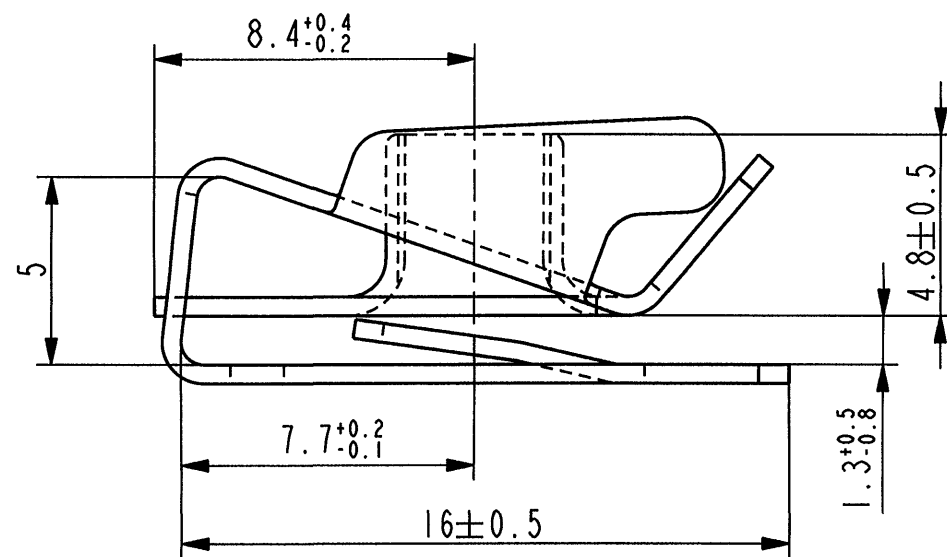

nicht bemaste Biegeinnenradien R0.8

© 015461 004	verzinkt / passiviert farblos	3250
015461 003	Zink-Nickel beschichtet / schwarzchromatiert	7601
015461 002	metallh. Korrosionsschutz- beschichtung, Farbe schwarz	5451
Teil-Nr. / Part-No.	Oberflaeche / Farbe / Finish / colour	Kennzahl/ Code number
Ausfuehrung / Execution		

Vor Auslegung einer automatisierten Verarbeitung des Teils
sollte Ruecksprache mit Fa. A.Raymond gehalten werden.
Fully automatic processing of the part requires prior
consultation with A.Raymond GmbH.

-	-	-	-	-
-	-	-	-	-
-	-	-	-	-
-	-	-	-	-
-	-	-	-	-
-	-	-	-	-
-	-	-	-	-
-	-	-	-	-
-	-	-	-	-
C	1x	Oberflaechenvariante hinzugefuegt	10.05.05	mj
B	1x	Werkstoff-Norm aktualisiert	06.12.04	mj
A	-	Indexreform, Art.-Nr. gem. SAP geaendert	02.11.04	mj
Ind.	Kompl vor/ kon offen	Beschreibung / Description	Datum/Date	Name

Aenderungen / Modifications

Format DIN A3 SPEZIALBEFESTIGUNGSSYSTEME WELTWEIT / ENGINEERED FASTENERS WORLDWIDE

Bei Verstaendnisproblemen beantragen Sie bitte beim Absender die deutsche Fassung vor jeder Anwendung.
"CONDITIONS OF USE"
This drawing and all information (the "Drawing") disclosed are the exclusive property of A.Raymond. By
using this Drawing the Addressee acknowledge and accept that this Drawing (1) is covered by A.Raymond'
intellectual property rights or know-how and (2) is provided under the following conditions who represent
a Deposit Agreement. This Drawing is for Addressee' internal use only limited to its estimation. Without
prior written consent of A.Raymond, no permission or rights for any purpose, is hereby granted, such as,
without any limitation, (1) the copy, in part or entirely (2) and/or the presentation, in part or entirely,
to any other third party outside the Addressee' company or in the company but with no interest (3) and/or
the distribution of the Drawing, in part or entirely, in any medium (4) and/or the creation of any deriva-
tive work. In case of breach of these conditions, Addressee shall indemnify A.Raymond from and against
all damages (compensatory or consequential), costs, expenses and charges, caused or arising out of or at-
tributable to its willful misconduct, fraud, negligence, infringement of A.Raymond' intellectual property
rights. If the Addressee does not accept these conditions, please notify A.Raymond' sender immediately.

Dateiname/ Filename	CAD-PE: 015461_C.01	vb
Ersatz fuer/ Substitute for	15461 Ind. 2 v. 29.04.1999	Proj.-Nr./ Proj.-No. Vol.(mm ³)
RASCH- Code	AABCA	Gewicht/ Weight (g)

Schutzrechte/ Patent rights	DBP 61		
Gepr./ App.	F.-gepr./ Produktion	Q.-gepr./ Quality	S.-gepr./ Patent app.
Masstab / Scale	5:1	Allgem.Tol. wenn nicht anders angegeben/ General tol. unless otherwise specified	Datum/ Date
		±0.3 / ±5°	02.11.2004
			Gez./ Drawn
			M. Junge

Oberflaechenbehandlg./ Finish	verzinkt / gelbchromatiert	Kennzahl/ Code number	3000
Werkstoffbehandlg./ Material treatment	zwischenstufenverguetet 365 ... 465 HV 5	Blechedicke/ Mat. Thickn. DIN EN 10 140	0.5
Werkstoff/ Material	ⓑ C 45 E DIN EN 10 132-3	Mat.-Code	1040

Benennung/ Part Name	Mehrbereichssteckmutter fuer Gewinde M4		
Teil-Nr./ Part-No.	015461 001		C