

Moyen de pose/Tool fitting : P4 177  
 Exemple d'utilisation/Use condition  
 Echelle/Scale : 1:1

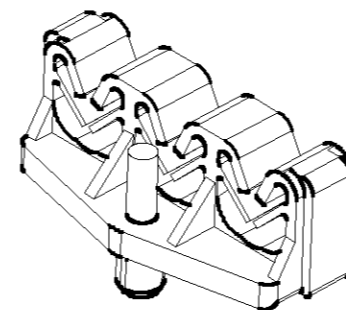

VUE ISOMETRIQUE/3D VIEW  
 ECHELLE/SCALE : 1:1

H=8.50 POUR/FOR Ø8.00  
 H=9.60 POUR/FOR Ø6.00  
 H=10.3 POUR/FOR Ø4.80

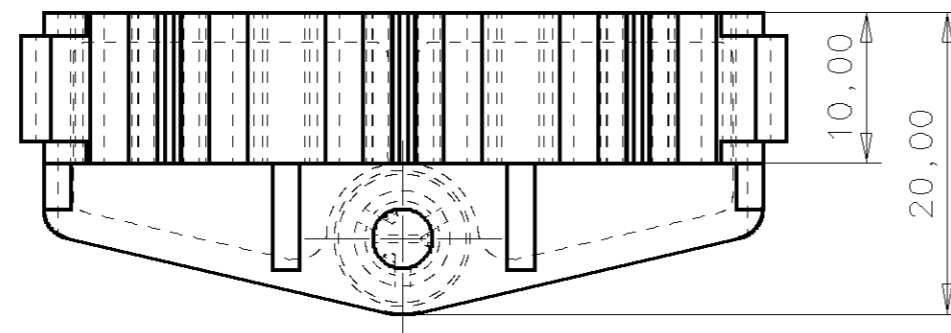
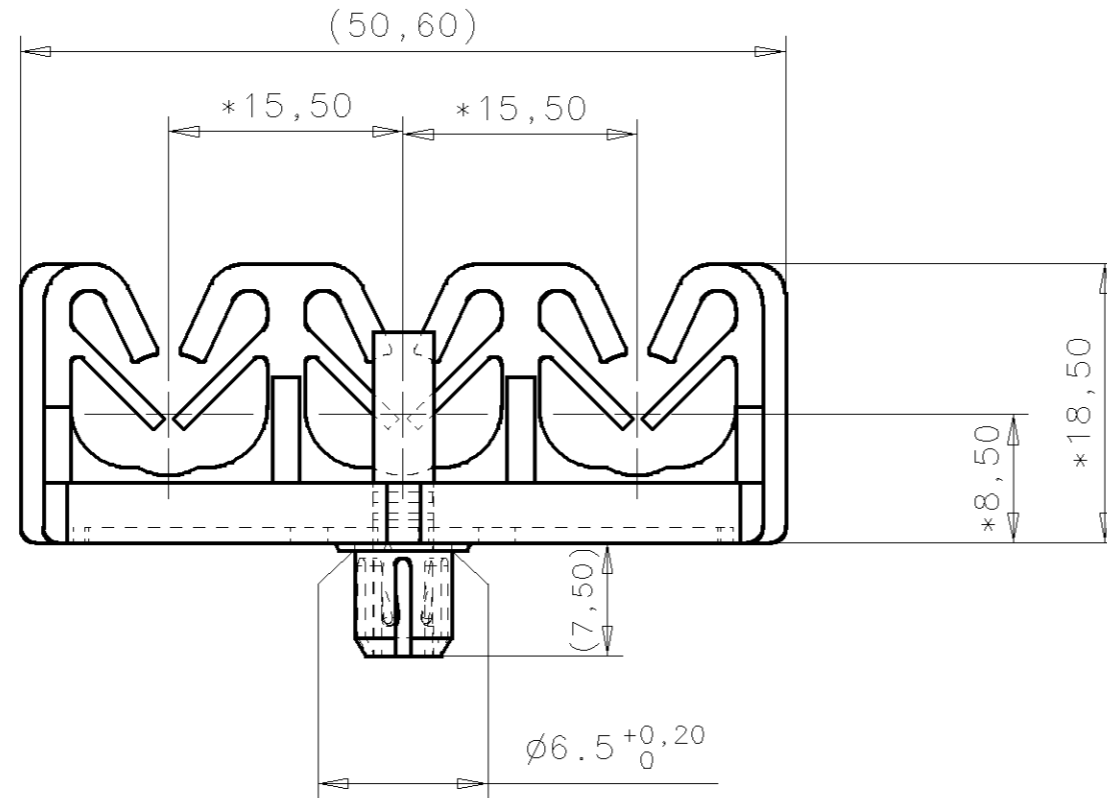
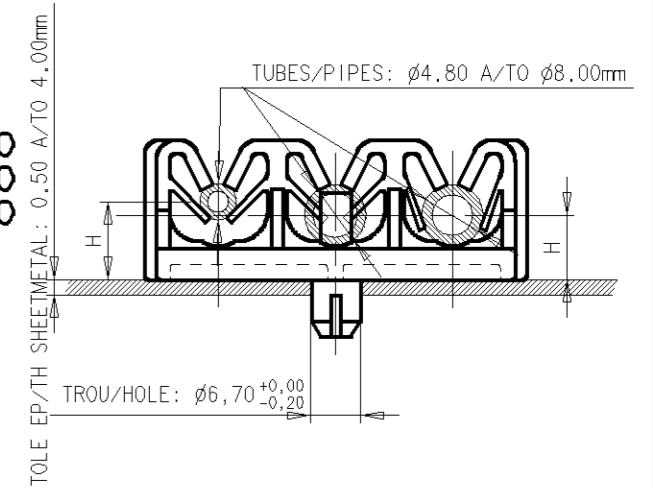

|     |        |                             |          |       |
|-----|--------|-----------------------------|----------|-------|
| Ab  | ---    | INTERNATIONAL DRAWING       | 28/05/09 | FA    |
| Aa  |        | Mise à jour SAP + 3D        | 12/12/05 | SP    |
| A   |        | DP 3707-> 064967            | 29/03/88 |       |
| IND | Nb DIM | DESCRIPTIONS / DESIGNATIONS | DATE     | VISAS |

**If the addressee does not accept these conditions, please notify A.Raymond sender immediately.**  
**Si problème de compréhension, merci de demander la version française à A.Raymond avant toute utilisation.**  
 This drawing and all information (the "Drawing") disclosed are the exclusive property of A.Raymond.  
 By using this Drawing the Addressee acknowledges and accepts that this Drawing  
 (1) is covered by A.Raymond intellectual property rights or know-how, and,  
 (2) is provided under the following conditions who represent a Deposit Agreement.  
 This Drawing is for Addressee' internal use only limited to its estimation.  
 Without prior written consent of A.Raymond, no permission or rights for any purpose, is hereby granted, such as, without any limitation,  
 (1) the copy, in part or entirely  
 (2) and/or the presentation, in part or entirely, to any other third party outside the Addressee' company or in the company but with no interest  
 (3) and/or the distribution of the Drawing, in part or entirely, in any medium  
 (4) and/or the creation of any derivative work.  
 In case of breach of these conditions, Addressee shall indemnify A.Raymond from and against all damages (compensatory or consequential), costs, expenses and charges, caused or arising out of or attributable to its willful misconduct, fraud, negligence, infringement of A.Raymond' Intellectual Property rights.

|        |  |           |           |          |                 |               |                             |          |
|--------|--|-----------|-----------|----------|-----------------|---------------|-----------------------------|----------|
| FORMAT |  | SCALE/ECH | TH/EP(mm) | VOL(mm3) | WEIGHT/POIDS(g) | SHEET/PLANCHE | TOLERANCE dimension / angle | DATE     |
| A3     |  | 2:1       |           |          |                 | 1/1           | ± 0.50 5                    | 16/10/79 |

SURFACE TREATMENT OR COLOR / TRAITEMENT DE SURFACE OU COULEUR:

**Noir**

MATERIAL TREATMENT / TRAITEMENT STRUCTURAL : ACHIEVED/REALISE: **AB**

**SANS** VISA:

MATERIAL / MATIERE: APPROVED/APPROUVE:

**PA 66 2D Noir (Type Radilon AUSZ 200 333 Noir) De RADICI** VISA:

TITLE / LIBELLE: **SUPPORT DE TUBES TRIPLE** PATENTS / BREVETS:

**3-PIPES CLIP**

CUSTOMER DATA / REF. CLIENT:

NUMBER / NUMERO:

**064967 .000**



113, cours Berriat .BP 157 .38019 Grenoble cedex 1 France ; Tel 04 76 33 49 49 ; Fax 04 76 48 20 50

I-Deas MS10 CAD FILE DO NOT MODIFY / PLAN REALISE EN CAO I-Deas MS10 NE PAS MODIFIER MANUELLEMENT

VERIFIER L ECHELLE APRES PHOTOCOPIE / BEWARE SCALE AFTER COPY

LES COTES \* DOIVENT ETRE VERIFIEES AVEC DES PIGES Ø8.1h8 ETANT AU PREALABLE MISES EN PLACE DANS LES LOGEMENTS.

\* DIMENSIONS HAVE TO BE CHECKED WITH Ø8.1h8 GAUGES IN THEIR SEATS.